



Assembly Instructions
wireSENSOR

Precautionary Measures

- Do not let the measuring wire rewind without control (snap back).
- > Danger of injury from whiplash effect of the wire with assembly bolts/clips, destruction of wire and/or of sensor
- Do not pull the measuring wire over range.
- > Damage to or destruction of the sensor is possible.
- Do not damage the measuring wire.
- Do not oil or grease the measuring wire.
- Do not bend the measuring wire.
- Do not pull the measuring wire at an angle.
- Do not allow to loop the measuring wire around objects.
- Do not fix the measuring wire to the target when wound up.
- Do not loop the measuring wire around parts of the body.

Sensor Assembly

Mount the sensor through mounting grooves for nut M4 DIN 934 or bolt M4 DIN 931 and/or through mounting clips MT60-WDS. The sensor does not have to be oriented in a special way. Choose the installation position so that damage and soiling of the measuring wire is avoided.

Proper Environment

- Protection class of sensor: IP 65¹
- Operating temperature: -20 bis +80 °C (-4 to +176 °F)
- Storage temperature: -40 bis +80 °C (-40 to +176 °F)
- Humidity: 5 - 95 % (no condensation)
- Ambient pressure: atmospheric pressure
- Vibration: according to IEC 68-2-6
- Mechanical shock: according to IEC 68-2-27
- EMC: according to EN 50 081-2 Spurious emission
EN 61 000-6-2 Resistance to disturbance

1) Models with male plug connection only with gasketed female plug

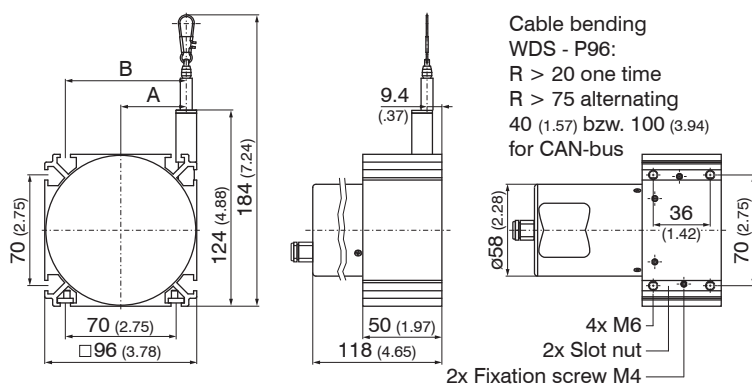

Dimensional drawing, WDS- ... - P96 - CA - P, dimensions in mm (inches)

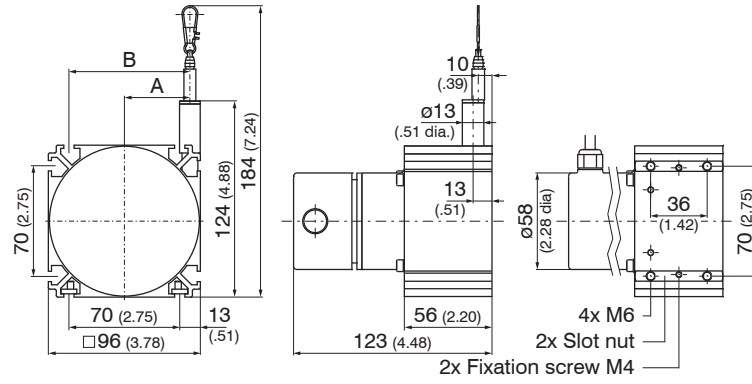

Dimensional drawing, WDS- ... - P96 - HTL/TTL, dimensions in mm (inches)

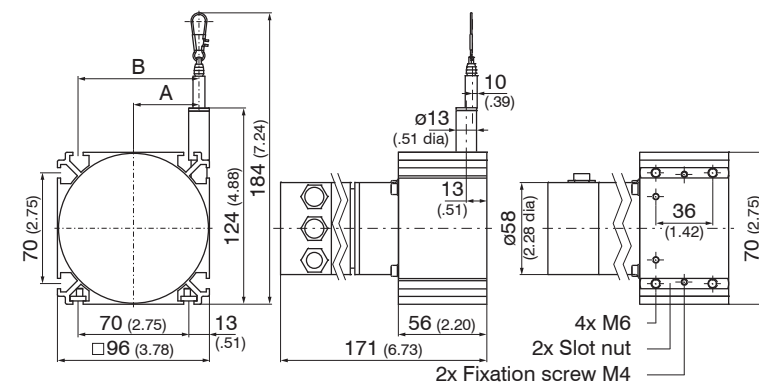

Dimensional drawing, WDS- ... - P96 - CO/PB, dimensions in mm (inches)

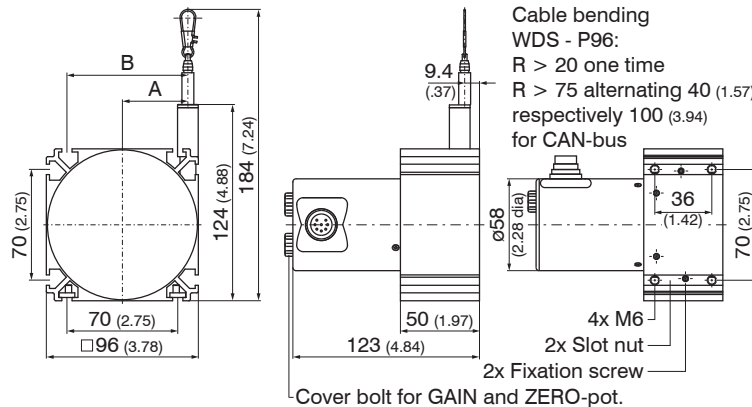

Dimensional drawing, WDS- ... - P96 - SR - U/I, dimensions in mm (inches)

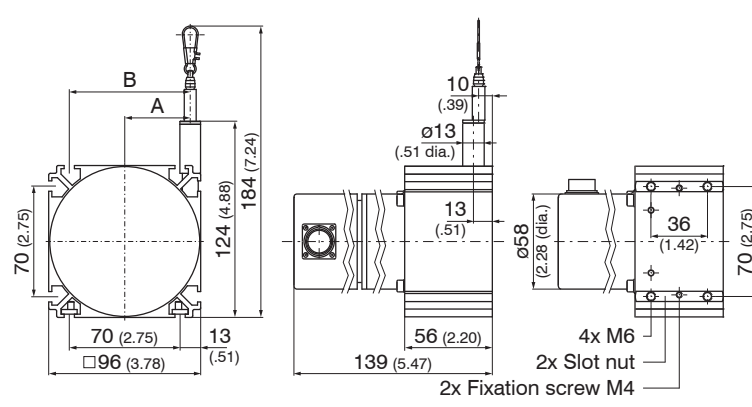

Dimensional drawing, WDS- ... - P96 - SSI, dimensions in mm (inches)

Model		A	B
WDS - P96 - CA - P	WDS-2000-P96	32 (1.26)	67 (2.64)
WDS - P96 - SR - U/I	WDS-2500-P96	41.4 (1.63)	76.4 (3.00)
WDS - P96 - HTL/TTL	WDS-2000-P96	26 (1.02)	61 (2.40)
WDS - P96 - SSI	WDS-3000-P96	41.4 (1.63)	76.4 (3.00)
WDS - P96 - CO/PB			

Dimensions in mm (inches)

Wire Guide and Fastening

Fix the measuring wire to the target using a wiring clip.

Fed the measuring wire perpendicularly from the sensor housing.

A misalignment is only permissible up to 3 degrees.

If you drag of the measuring wire on the inlet hole or other objects, this leads for damaging and/or snapping of the measuring wire.

If you cannot fed the measuring wire vertically out of the housing, it is essential to use a guide pulley (accessory TR1-WDS).

Keep the measuring wire in an area where it cannot be snagged or otherwise be violated.

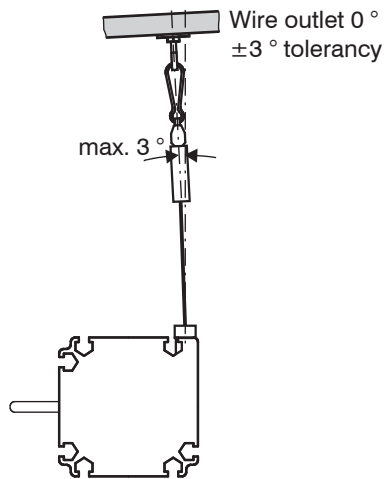

Dimensional wire fastening and misalignment

For further information, please refer to the online documentation.

You will find the latest version at:

www.micro-epsilon.com/link/wire

> "wireSENSOR WDS-P60 / P96 Analogue" or

"wireSENSOR WDS-P115 Analogue".

Power Supply and Display/Output Device

Electrical connection		Output
- CR - integrated cable	- SR - connector	- P - potentiometer
color DIN 47 100	Pin	
white	1	input +
brown	2	ground
green	3	signal
screen	screen	housing

Connection pin assignment WDS- ... - Pxx - CR - P

Electrical connection	Output	
-- SR- ¹ device plug DIN 45 326	- U voltage	- I current
Pin - Nr.		
1	supply +	
2	ground	
3	signal	---
4	ground (signal)	---

Connection pin assignment WDS- ... - Pxx - SR - U/I

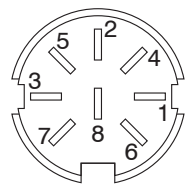

View of solder pin side 8-pole female cable connector

1) Pin 5 - 8 are not connected.

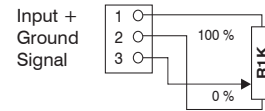
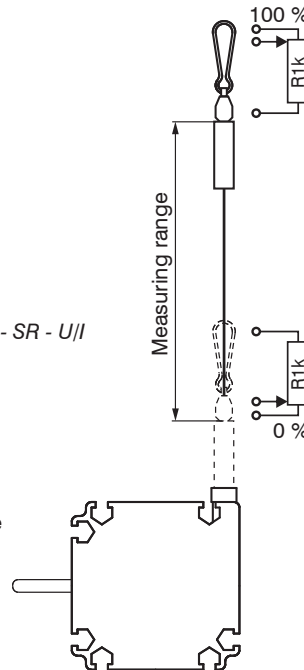

Model with potentiometer output

A pre-assembled connecting cable PC3/8 is available as an accessory.

Note for the user-side assembly of a cable:

- Use a screened cable.
- Earth the screen on electronics side.
- Recommended conductor cross-section 0.14 mm² (up to 9 m/30 ft cable length)
- Maximum cable diameter 8 mm / 0.3 inch

Note the pin assignment for draw-wire displacement sensors with **encoder output**. The sensor contains an additional supplement for detailed information.

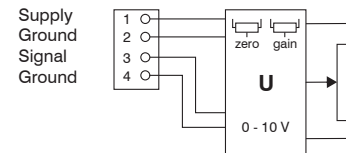

Model with voltage output

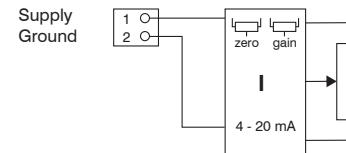

Model with current output

Operation

Draw wire sensors with voltage output (U) or current output (I) are equipped with integrated electronics with setting potentiometers (trimmers) for zero and gain. The access holes for the trimmers are located in the housing cover. With the zero trimmer the zero point can be shifted by ±20 % of the range with voltage output (±18 % with current output). With the gain trimmer the signal span (sensitivity) is adjusted by ±20 % with voltage output (±15 % with current output). For draw wire sensors with encoder output (E, A) there are no adjustment and setting elements.

Declaration of incorporation

MICRO-EPSILON MESSTECHNIK
GmbH & Co. KG

Königbacher Straße 15
D-94496 Ortenburg

Declaration of incorporation as defined by the EC Directives Machinery 2006/42/EC, Annex II, section B

We herewith declare that the partly completed machinery

Type of machinery: wiresensor,

Type/Model: WDS-xxx, WPS-xxx

fulfills the relevant essential requirements of the EC Directives Machinery 2006/42/EC and depending on the delivery the EC Directives Electromagnetic Compatibility 2004/108/EC.

Furthermore, we declare that the relevant technical documentation for this partly completed machinery is prepared as described in Annex VII, part B. We commit ourselves to transmit the relevant technical documentation to the national authorities on request.

The partly completed machinery must not be put into service until the machinery into which it is to be incorporated has been declared in conformity with the provisions of the EC Machinery Directives and for which a declaration of conformity exists referred to Annex II A.

Ortenburg, April 15th 2009

Dipl.-Phys. Johann Salzberger
Managing Director



X9771034.02-A020099HDR