

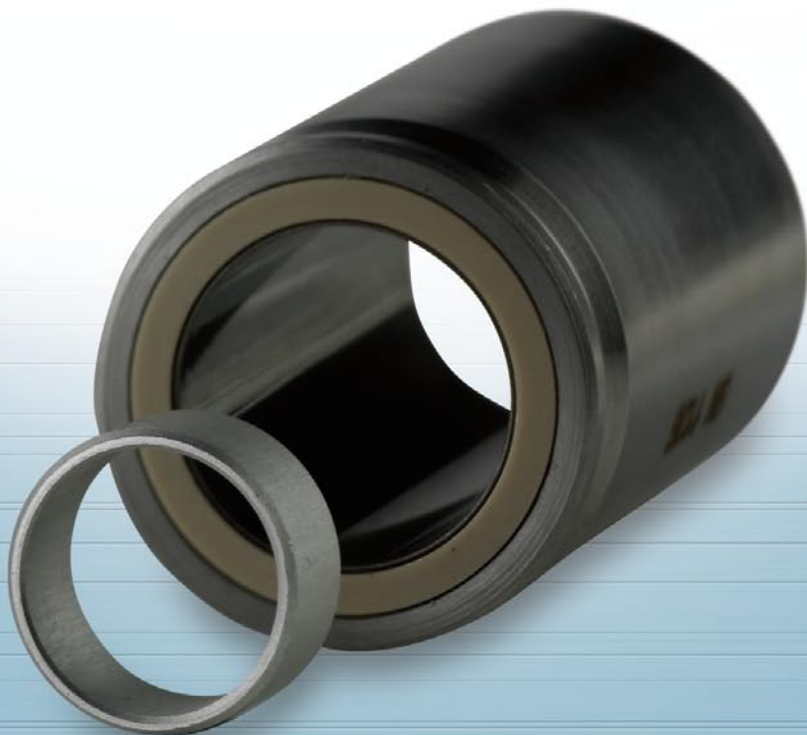

# More Precision.

**clampCONTROL**

Clamping stroke monitoring in tool spindles



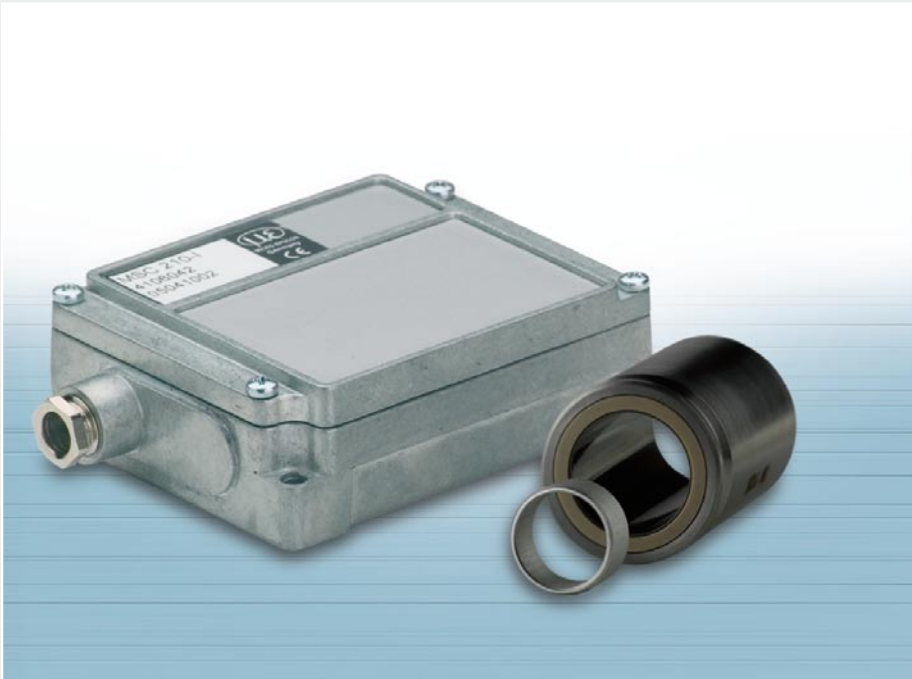

- Short sensor construction and huge measurement range
- Compact integral sensor
- Non-contact and wear-free measurement principle
- Adjustment is not required
- High resolution

### Applications

clampCONTROL has been specially designed to monitor the tool position in high performance spindles. The sensor is integrated into the spindle and directly measures the clamping stroke of the drawbar. It can be universally used with a wide range of spindles due to its extremely compact design.

### Measuring principle

clampCONTROL operates by utilising a novel, inductive measuring principle. The clear advantage from this is a more favourable relationship between the measuring range to the length of the sensor. This means that the sensors can be optimised and integrated with a spindle even when space is restricted. Potential areas of application are where high accuracy is required, but where contact measurement techniques (potentiometer, draw-wire sensors, etc.) cannot be used due to difficult, harsh ambient conditions.

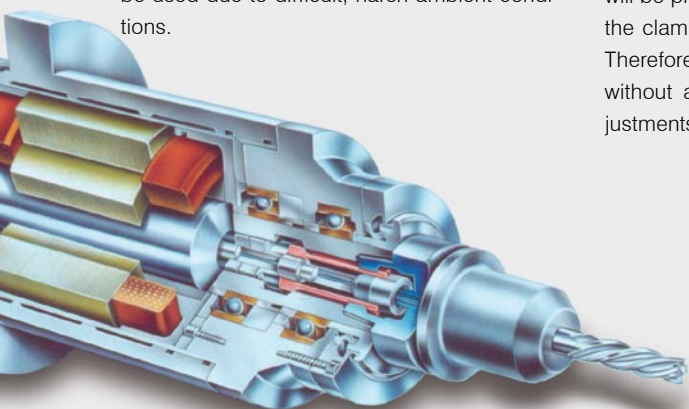

The mechanical travel is transferred to the sensor without contact using the drawbar located aluminium ring. A linear output signal or switch signal is obtained depending on the position of the ring. The non-contact measuring principle ensures a longer sensor life. Precise concentric guidance of the ring in the sensor is not necessary.

### In Practice

Previously, proximity sensors and connector rings, which supplied a switching signal, were used for monitoring the clamped position. However, this had to be adjusted and sensor set up was complicated. clampCONTROL offers a significant improvement here. The sensor is integrated into the release unit and directly measures the clamping stroke of the drawbar. An analogue signal or a switching signal will be provided due to the lifting movement of the clamping stroke while tensioning the tool. Therefore, continuous monitoring is possible, without any time-consuming mechanical adjustments of the switch point.

### System configuration

Depending on the electronics used, either analogue output (2 ... 10 V bzw. 4 ... 20 mA) with system configuration 1 or alternatively 3 high-side switching outputs ("Clamping without tool", "Clamped with tool", "Tensioner opened") with system configuration 2 are possible. The switching points can be set anywhere within the measuring range.

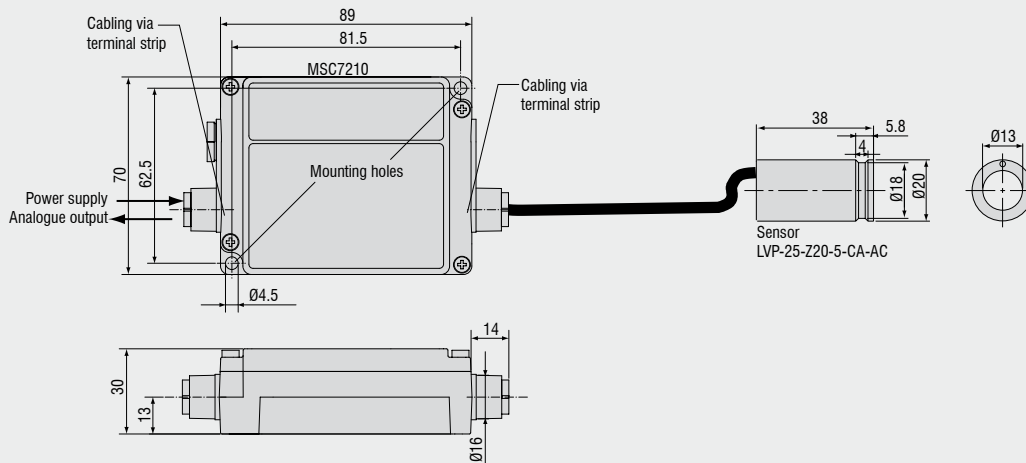
**System configuration 1 (Analogue output):**

Technical data	Sensor LVP-25-Z20-5-CA-AC	
Measuring range	25mm	
Linearity	< ±1% FSO	
Operating temperature	0 ... +120°C	
Storage temperature	-20 ... +130°C	
Temperature stability	< ±0.02 % FSO/°C	
Shock	40g, 3000 per axis (IEC 68-2-29)	
Vibration	5Hz ... 44Hz ± 2.5mm / 44Hz ... 500Hz ±20g (IEC 68-2-26)	
Ambient pressure	6 x 10 <sup>5</sup> Pa	
Cable	Integrated cable, Ø 3mm, length 2m <sup>1</sup> ; turns <10; bending radius 10mm (singular), 30mm (durable)	
Target	Anodised aluminium, target mounting: Pasted on clamping cylinder (e.g. LOCTITE 2701)	
Clamping cylinder	Material: 31CrMoV9V, material-no. 1.8519.05; constant diameter at measuring range, Ø 8mm	
Protection class	IP 67 (without cable, sealed cable ends)	
Technical data controller	MSC7210-U	MSC7210-I
Power supply	18 ... 30VDC	
Protection	Polarity reversal and overvoltage protection	
Range	gain: -20 ... +270% FSO (trimpot) / zero: ±70% FSO (trimpot)	
Signal output	2 ... 10VDC	4 ... 20mA
Noise	< 1.5mV <sub>eff</sub> <sup>2</sup>	< 3µA <sub>eff</sub> <sup>2</sup>
	< 15mV <sub>ss</sub>	< 30µA <sub>ss</sub>
Linearity	< ±0.02% FSO	
Frequency response	300Hz	
Temperature range	storage: -40°C ... +85°C / operating: 0...+70°C	
Temperature stability	±100ppm / °C	
Housing material	Zinc die cast	
EMV	EN 50 081-2 spurious emission / EN 50 082-2 immunity to interference	
Protection class	IP 65	
Shock	15g, 1000 per axis (IEC 68-2-29)	
Vibration	20 ... 500Hz	
Sensor connection	plug-in screw clamp 4-pol.	
Signal/supply connection	plug-in screw clamp 5-pol.	

FSO = Full Scale Output

<sup>1</sup> shorter lengths on request

<sup>2</sup> RMS AC Measurement, frequency 3Hz ... 300Hz

## System configuration 2 (High-side switching outputs):

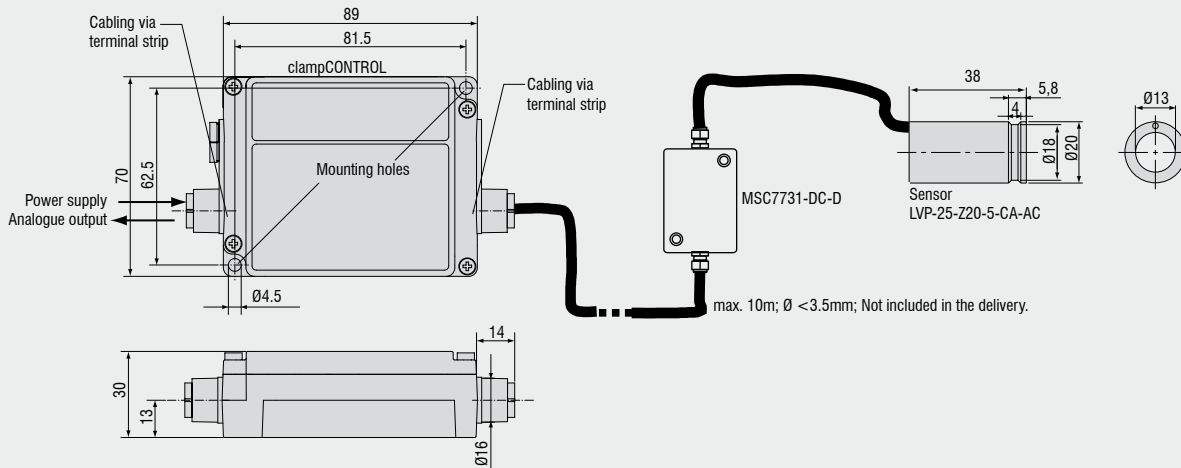

Technical data	Sensor LVP-25-Z20-5-CA-AC
Measuring range	25mm
Linearity	$< \pm 1\%$ FSO
Operating temperature	0 ... +120°C
Storage temperature	-20 ... +130°C
Temperature stability	$< \pm 0.02\%$ FSO/°C
Shock	40g, 3000 per axis (IEC 68-2-29)
Vibration	5Hz ... 44Hz $\pm 2.5\text{mm}$ / 44 Hz ... 500Hz $\pm 20\text{g}$ (IEC 68-2-26)
Ambient pressure	$6 \times 10^5$ Pa
Cable	Integrated cable, $\varnothing 3\text{mm}$ , length 2m <sup>1</sup> ; turnings $< 10$ ; bending radius 10mm (singular), 30mm (durable)
Target	Anodised aluminium; target mounting: Pasted on clamping cylinder (e.g. LOCTITE 2701)
Clamping cylinder	Material: 31CrMoV9V, material-no. 1.8519.05; constant diameter at measuring range, $\varnothing 8\text{mm}$
Protection class	IP 67 (without cable, sealed cable ends)
Technical data controller	MSC7731-DC-D electronics + clampCONTROL
Power supply	12 ... 30VDC
Protection	Polarity reversal and overvoltage protection
Switching outputs	High-side power switch / maximum current 0.5A per output, short-circuit proof
Temperature range	storage: -40°C ... +85°C / operating: -40...+70°C
Housing material	zinc die cast
EMV	EN 50 081-2 spurious emission / EN 50 082-2 immunity to interference
Protection class	IP 65
Shock	15g, 1000 per axis (IEC 68-2-29)
Vibration	20 ... 500Hz
Sensor connection	Terminal strip
Signal/supply connection	Terminal strip

FSO = Full Scale Output  
<sup>1</sup> shorter lengths on request