

turboSPEED series TSSC OEM-Sensor for turbocharger speed measurement

How it works

The sensor operates according to the eddy current principle: A coil in the tip of the sensor is energized by a high frequency alternating current. The electromagnetic field thus produced is changed when a turbocharger blade approaches. In this way, each blade generates an impulse which is conditioned in the ASIC electronics. A pre-installed divisor (equals the number of blades on the compressor turbine) insures that one pulse per revolution of the turbocharger shaft, with a duty cycle of 40 to 53%, is provided on its Open Drain NMOS output. If a sensor error occurs, an output signal with 75% duty cycle is produced or optionally LOW is output. The electronics unit is permanently fixed to the sensor.

Features

- Both aluminium as well as titanium vanes are recognized
- Prior setting of the turbine number of vanes (8 to 23)
- Recognition of sensor errors
- 5V power supply
- Short-circuit protection up to $\pm 30V$
- Continuous temperature resistance up to 140°C (continuous operation) or up to 180°C (for a short time)

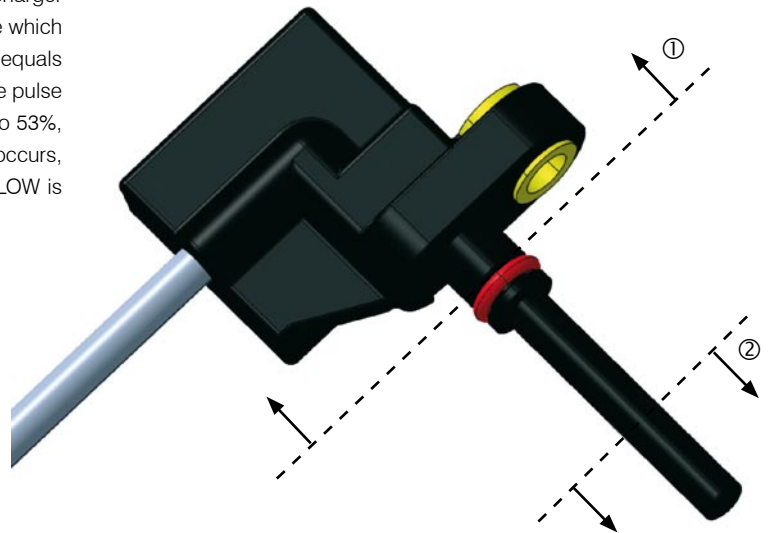

Temperature profile (area ①)

Temperature range °C	Time in h
-40...105	14500
105...125	2000
125...140	1300
140...150	1100
150...160	1100
160...170	50
170...180	50
sum:	20000

Temperature profile (area ②)

Temperature range °C	Time in h
-40...200	continuous
200...230	1000

More Precision



Sensor data

Operating conditions	Min	Max	Typical
Supply voltage	4.75V	5.25V	5V
Current consumption		5mA	3.5mA
Ambient temperature (temperature profile)	-40°C	170°C	
External pullup resistance at RPM ($V_{pullup} = V_{supply}$) (high-level)	3.3kOhm	15kOhm	
Low-level at RPM ($I_{RPM} \leq 1,5 \text{ mA}$)	0.25V	0.75V	
Short circuit current at RPM (at $V_{RPM} = 5 \text{ V}$)	5.6mA	8.8mA	
Overvoltage cutoff at RPM ($I_{RPM} \leq 0,2 \text{ mA}$)	5.5V	10V	
Overvoltage cutoff at power supply	5.5V	6.5V	6V
Start-up time after power on		100ms	
Duty cycle at RPM (general duty, all vanes detected)	40%	53%	
Duty cycle at RPM (module error = internal error)	70%	80%	75%
Frequency at RPM (module error = internal error)	3kHz	7kHz	5kHz
Alternative at RPM (module error = internal error) – option		Low-level at RPM	

Absolute limits	Min	Max
Temperature range	-40°C	180°C
Storage temperature	-40°C	125°C
Supply voltage	-0.3V	5.5V

Voltage to GND (per short circuit at $\leq (12...30V)$, over life cycle accumulated max. 180s):

Power supply	-30V	30V
RPM	-30V	30V

EMC-resistance (Group D, Status 1)

Life cycle 20000h

Error

Short circuit	Level at controller
5V -> GND	5V
5V -> Output	5V
Output -> GND	GND

Open circuit	Level at controller
5V	5V
Output	5V
GND	5V

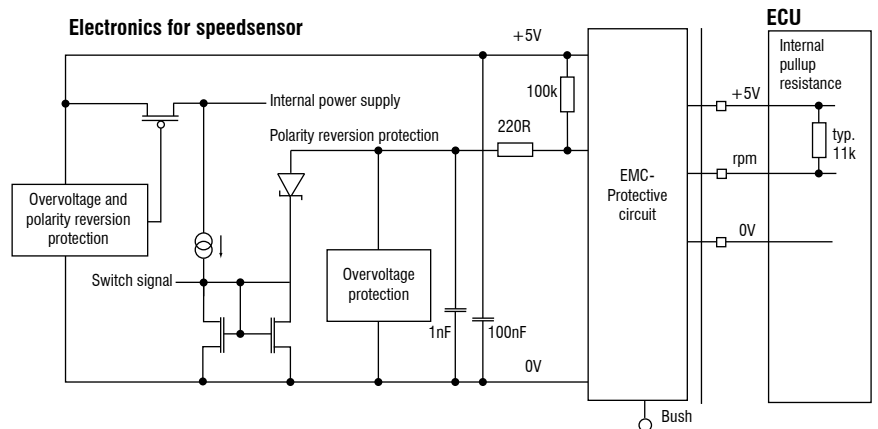

Micro-Epsilon

94496 Ortenburg / Germany
 Tel. +49 (0) 8542 / 168-0
 certified DIN EN ISO 9001 : 2000

info@micro-epsilon.com
 www.micro-epsilon.com
 Modifications reserved / Y9761238-A031120DGO

HIRSCHMANN AUTOMOTIVE GmbH

6830 Rankweil / Austria
 Tel. +43 (0) 5522-307-0

info@hirschmann-automotive.com
 www.hirschmann-automotive.com

