

Warnings

- Do not open the sensor housing.
 - Do not pull or loop the measuring wire around unprotected body parts.
 - Do not pull out the measuring wire beyond the measuring range listed.
 - Do not let the measuring wire snap.
- > Risk of injury
- Do not damage the measuring wire.
 - Do not oil or grease the measuring wire.
 - Do not kink the measuring wire.
 - Do not pull the measuring wire diagonally.
 - Do not let the measuring wire drag around objects.
 - Attach the measuring wire to the measured object while the wire is retracted.
- > Damage to or destruction of the sensor

Sensor Mounting

- ➔ Mount the sensors as follows:
- Z60 series: Mounting through mounting holes for 2x M4 DIN 931 screws
 - P96 series: 4x M6 DIN 931 and 2 slot nuts
 - P115 series: 4x M6 DIN 931 and 2 slot nuts
 - P200 series: 4x M8 DIN 912 and 4 slot nuts

The slot nuts can be mounted on each sensor side and positioned as desired.

The sensor does not have to be oriented in a special way.

- ➔ Select the installation position in such a way that damage to or contamination of the measuring wire is avoided.

ⓘ If possible, prefer an installation position in which the measuring wire exits downward. This prevents liquids from entering the measuring wire outlet.

Proper Environment

- Protection class: Depending on encoder
- Temperature range:
 - Operation: -20 ... +80 °C (-4 ... +176 °F)
 - Storage: -40 ... +80 °C (-40 ... +176 °F)
- Humidity: 5 ... 95% (non-condensing)
- Ambient pressure: Atmospheric pressure
- Vibration: According to DIN EN 60068-2-6
- Shock: According to DIN EN 60068-2-27

Installing the Encoder

WDS-Pxxx Series

- ➔ Fix the coupling half to the encoder shaft. Mount the flange on the encoder (rotary encoder).
- ➔ Mount the encoder/flange assembly on the draw-wire mechanism.

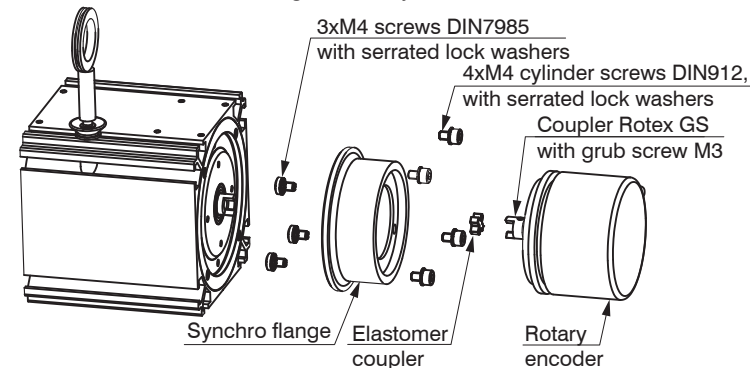

Mounting of flange and encoder, WDS-Pxxx

WDS-Z60 Series

- ➔ Mount the flange on the encoder (rotary encoder). Connect the shaft of the encoder to the shaft of the draw-wire mechanism.
- ➔ Mount the encoder/flange assembly on the draw-wire mechanism. Press the supplied sealing cap into the opening in the flange housing.
- ⓘ Make sure that the measuring wire is always tensioned by the spring motor in order to prevent it from jumping off the cable drum.

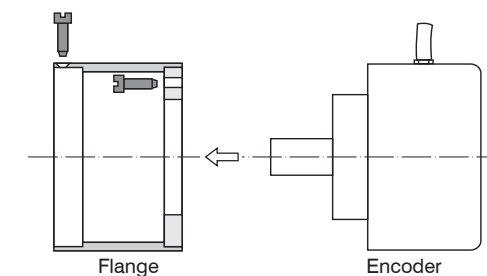

Mounting of flange and encoder, WDS-Z60

ⓘ Applies to both series: Make sure that the encoder shaft is not rotated during installation. Observe the installation instructions provided by the encoder manufacturer.

Guiding and Attaching the Wire

If the measuring wire must be pulled out of the sensor to guide the wire or attach it to the measured object:

- the sensor must not be held by a second person during that process,
- the measuring wire must not be pulled out beyond the measuring range listed,
- the area around the sensor must be protected against snapping of the measuring wire.

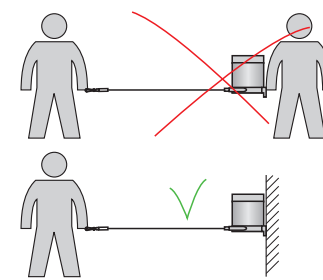

- ➔ Fix the measuring wire to the target using a wire clip/threaded bolt/eyelet.

- ➔ Guide the measuring wire vertically out of the sensor housing.

Diagonal pull is only permitted up to 3 degrees.

If you drag the measuring wire over the insertion hole or other objects, the measuring wire will be damaged and/or tear.

ⓘ If the measuring wire cannot be fed vertically out of the housing, it is essential to use a guide pulley, also see Optional Accessories in the Appendix of the Operating Instructions.

- ➔ Guide the measuring wire in a protected area so that it cannot get caught or otherwise be damaged.

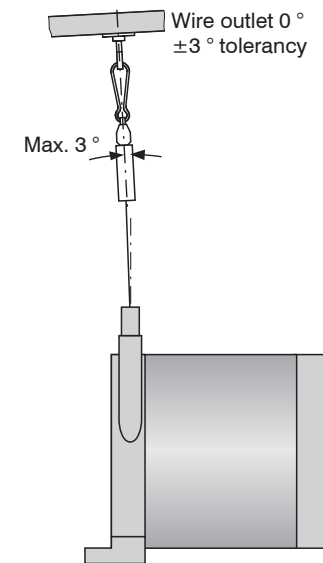

Attachment and maximum diagonal pull of the measuring wire

Declaration of Incorporation

Declaration of incorporation according to EC Machinery Directive 2006/42/EC, Annex II B

The manufacturer and person authorized to compile the relevant technical documents

MICRO-EPSILON MESSTECHNIK GmbH & Co. KG
Königbacher Straße 15, 94496 Ortenburg / Germany

hereby declare that the machine designated below complies with the relevant fundamental health and safety requirements of the EC Machinery Directive, including modifications to it applicable at the time of this declaration, based on its design and construction and in the version put on the market by us – to the extent that the scope of supply allows.

Machine design: Draw-wire sensor
(mechanics and models with potentiometer output)

Type designation: WDS-xxx, WPS-xxx

The following fundamental health and safety requirements according to Annex I of the directive specified above have been applied and complied with:

- No. 1.1.2. Principles of safety integration
- No. 1.7.3. Marking of machinery
- No. 1.7.4. Operating instructions

Furthermore, we declare compliance with the following directives and standards including the modifications applicable at the time this declaration is made:

- Directive 2006/42/EC (machinery)
 - EN ISO 13857:2019 Safety of machinery - Safety distances to prevent hazard zones being reached by upper and lower limbs
 - EN 60204-1:2018 Safety of machinery - Electrical equipment of machines - Part 1: General requirements
- Directive 2011/65/EU (RoHS)
 - EN IEC 63000:2018 Technical documentation for the assessment of electrical and electronic devices with respect to the restriction of hazardous substances

We also declare that the special technical documentation for this partially completed machine has been created in accordance with Annex VII, Part B, and commit ourselves to disclose this to the market surveillance authorities upon request. The commissioning of these partially completed machines is prohibited until the partially completed machine(s) has/have been installed in a machine that meets the requirements of the EC Machinery Directive and for which an EU Declaration of Conformity according to Annex II, Part A exists

Ortenburg, Germany
July 1, 2021

Dipl.-Ing.(FH) Eduard Huber, MBA
Quality Manager



Assembly Instructions
wireSENSOR
Serie WDS
Z60/P96/P115/P200



Dimensional Drawings

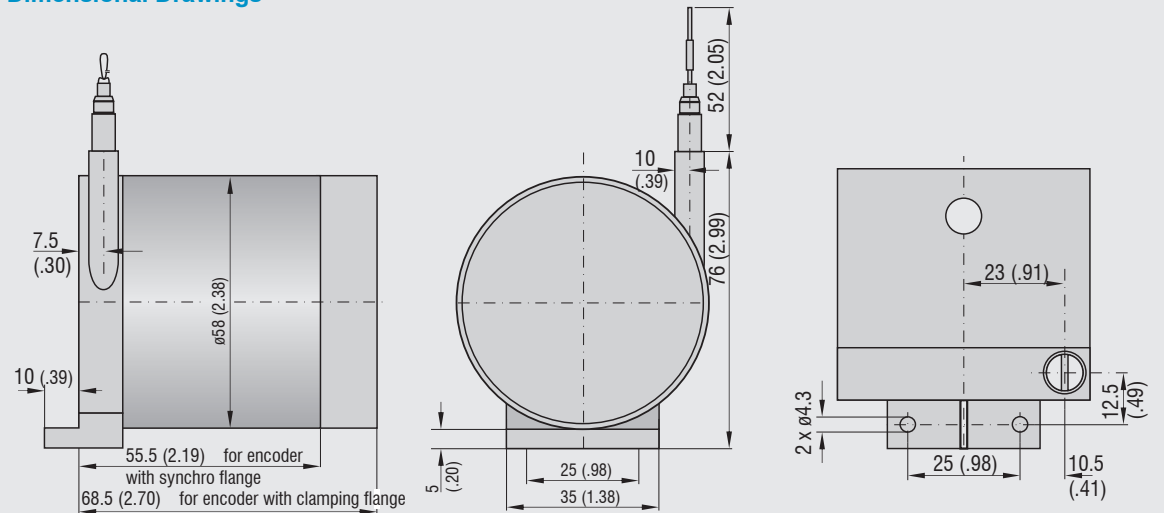

WDS-Z60-M series,
dimensions in mm (inches)

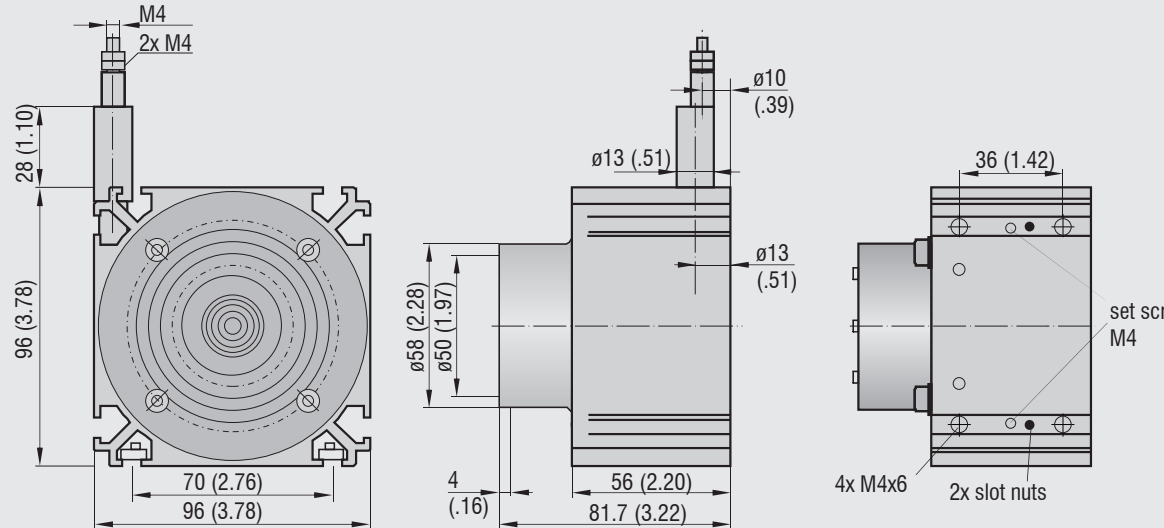

WDS-P96-M series,
dimensions in mm (inches)

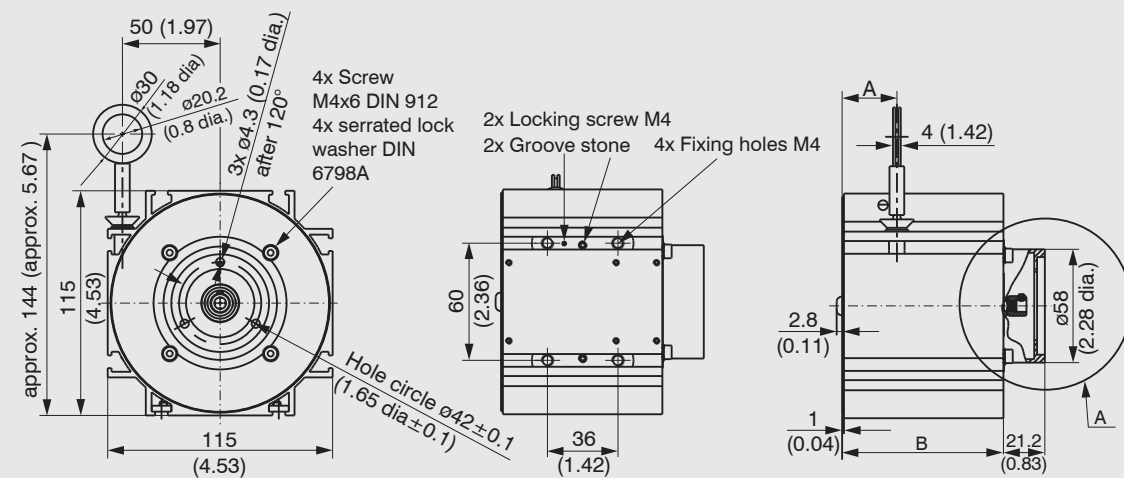

WDS-P115-M series, dimensions in mm (inches)

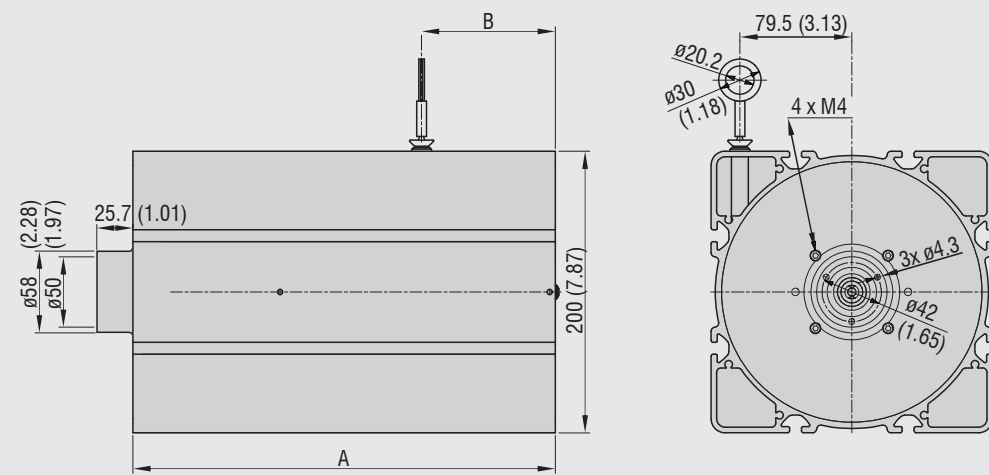

WDS-P200-M series, dimensions in mm (inches)

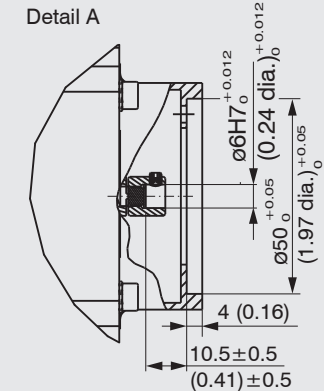

Measuring range	A	B
5000	28	82,5
7500	37	105,5
10000	44,5	148,5
15000	61	180,5

Measuring range	A	B
30000	268	75
40000	300	95
50000	333,5	95

You can find more information about the sensor in the operating instructions. They are available online at

<https://www.micro-epsilon.com/fileadmin/download/manuals/man--wireSENSOR-Z60-P96-P115-P200-Mechanik--de-en.pdf>

MICRO-EPSILON MESSTECHNIK GmbH & Co. KG
Koenigbacher Str. 15 • 94469 Ortenburg / Germany
Tel. +49 8542 / 168-0 • Fax +49 8542 / 168-90
info@micro-epsilon.com • www.micro-epsilon.com

Your local contact: www.micro-epsilon.com/contact/worldwide/