



More Precision

reflectCONTROL Automotive

The leading automotive surface inspection system



Fully automatic surface inspection reflectCONTROL Automotive

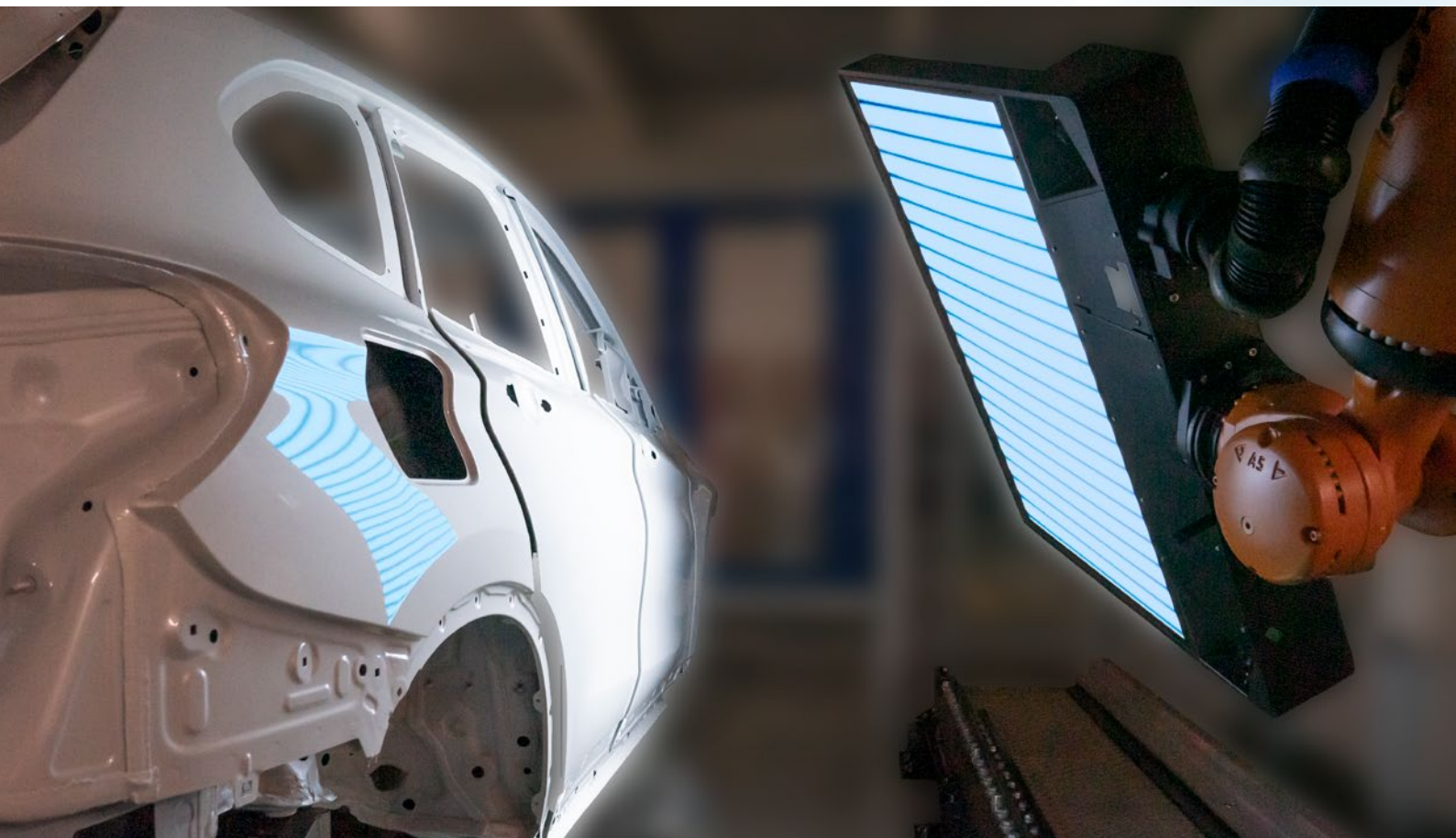

The leading automatic surface inspection

reflectCONTROL Automotive enables the fully automatic inspection of painted car bodies. These robotic systems enable the detection, three-dimensional measurement and classification of typical paint defects such as inclusions, craters and runners.

Due to their high efficiency, the reflectCONTROL systems are superior to conventional light tunnels and static systems. Impressing with high precision and repeatability, these systems can be easily combined with automatic processing systems. This is how reflectCONTROL Automotive enables a fully automatic process from paint defect inspection and evaluation to automatic post-processing.

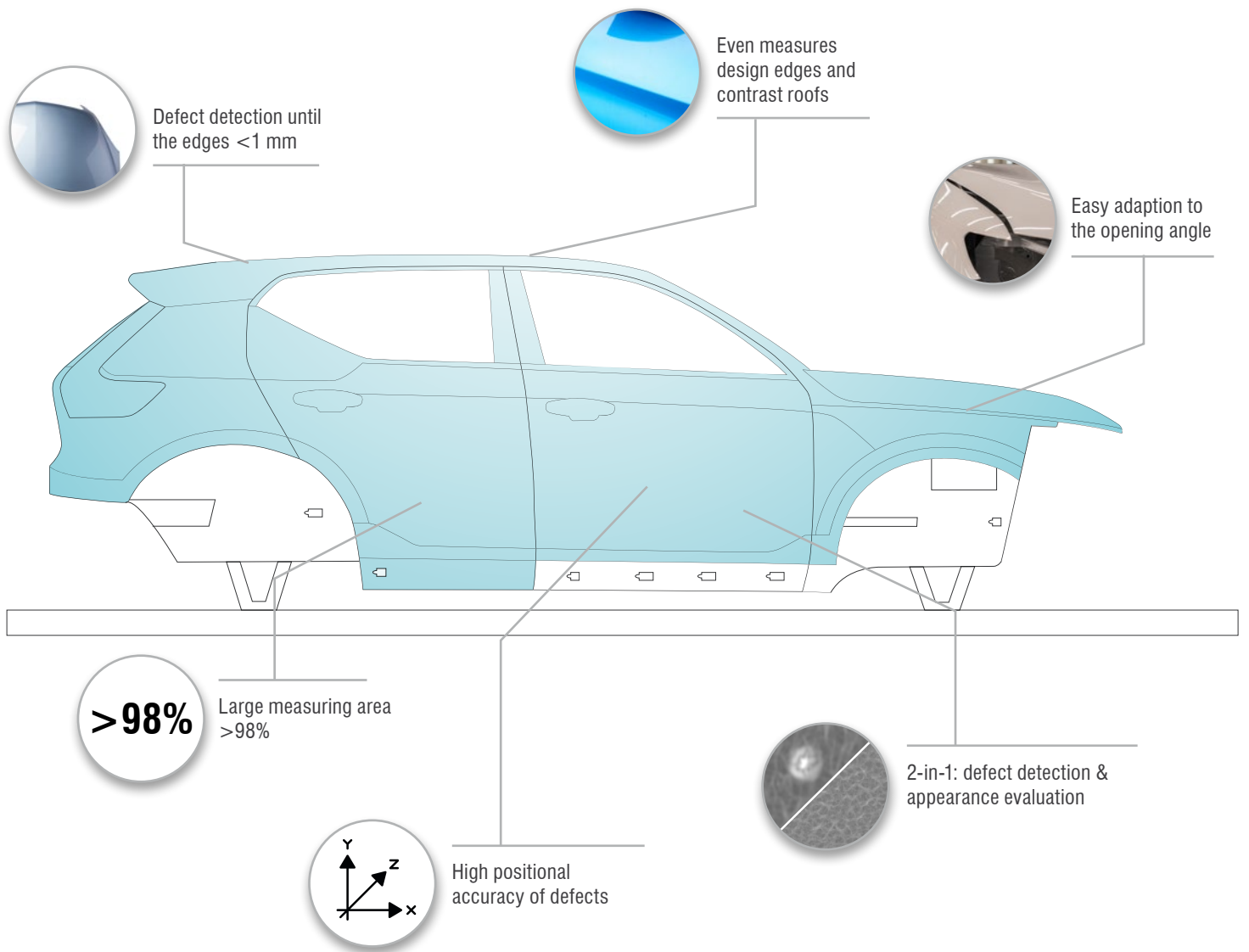

Superior technology for automatic defect detection

The measuring principle of phase-shifting deflectometry enables objective inspection processes regardless of human factors such as tiredness or lack of concentration. Smart image processing algorithms convert the measured data into three different channels: local curvature, reflectivity and base intensity. By intelligently evaluating these channels, anomalies in shape, reflectivity and contrast are identified.

Software package reflectCONTROL Automotive



Powerful software

In addition to measurement hardware, the reflectCONTROL systems comprise a powerful software platform which includes set-up and path planning tools. The rcViewer is for 3D defect view and full car body view including evaluation zones. An integrated Appearance Viewer displays the defined surface evaluation zones.

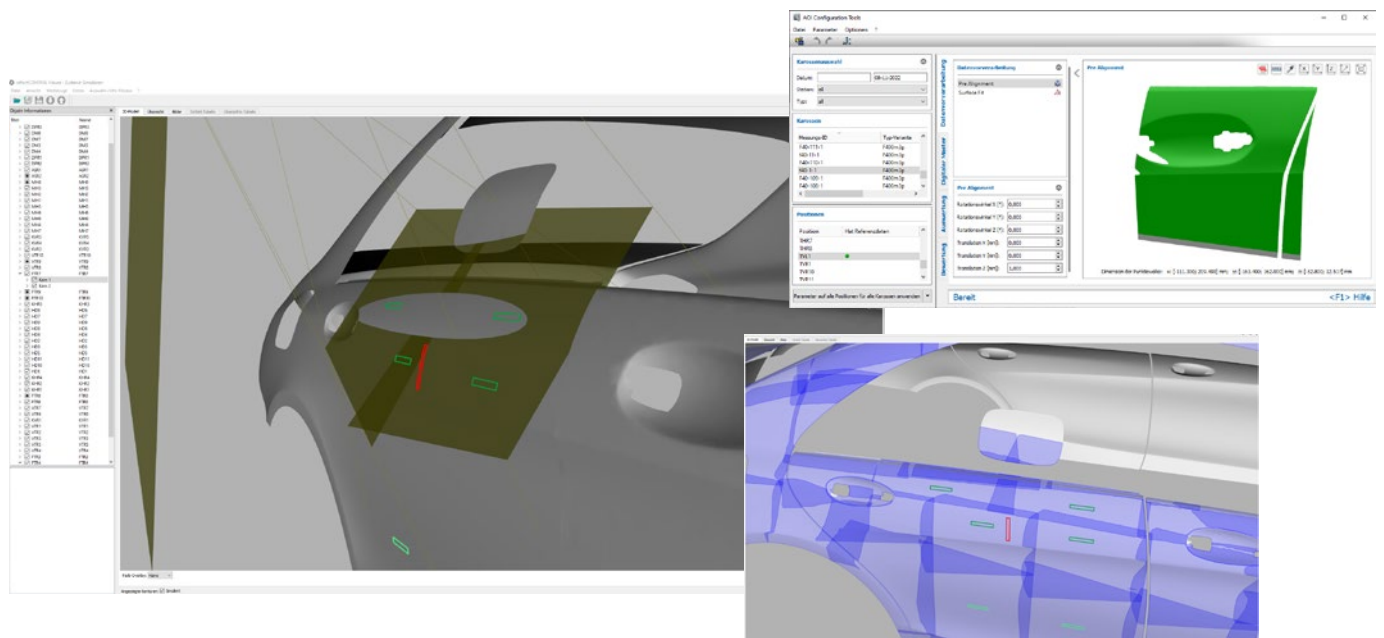
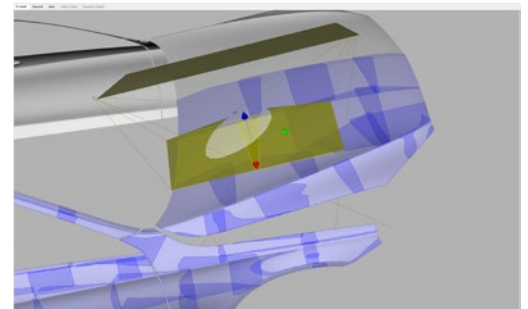

Unrivalled detection rate with reflectCONTROL

Visual surface inspection normally achieves a detection rate of merely 65%. Even when the offline inspection is time-consuming, no more than 78% of defects can be found.

With reflectCONTROL Automotive, car manufacturers achieve a detection rate of more than 98.5% - always reproducible, regardless of the body color and the performance of the auditor. Precise 3D defect reconstruction achieves maximum congruence with the auditor's specifications. Due to the high positional accuracy of the defects, the latter are detected and located precisely which is the basis for subsequent, automatic post-processing.

The inspection system achieves outstanding area coverage and detects defects up to <1 mm from the edges. It also measures design edges and is flexible enough to allow easy adaption to the opening of movable components such as doors and flaps.

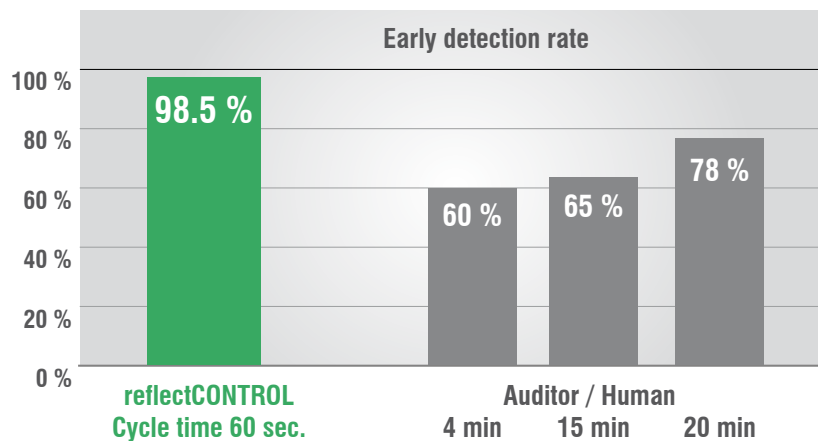

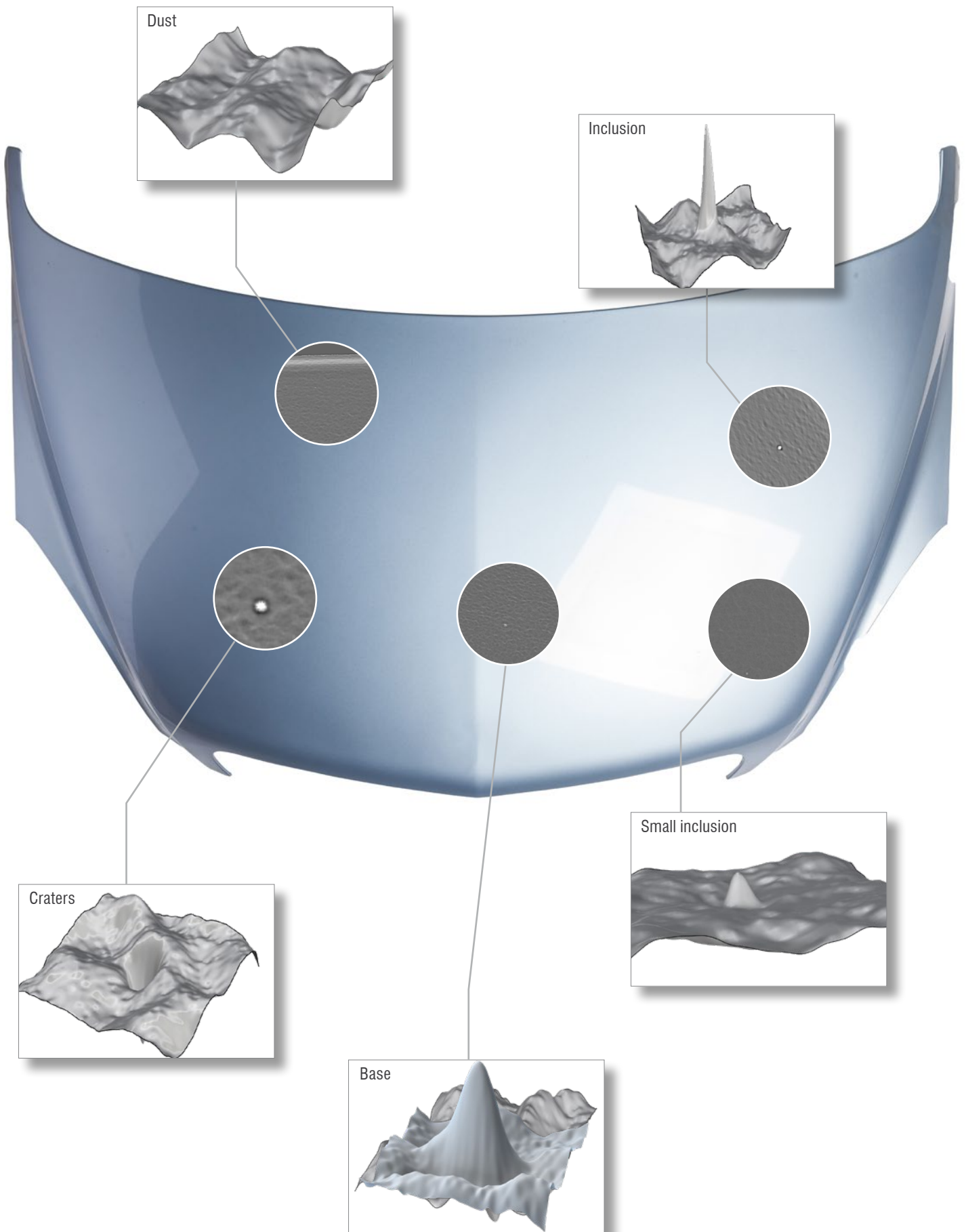

AI-based classification

The reflectCONTROL classification can be optimized using AI. For this purpose, Micro-Epsilon offers a tool that can be trained with defect data by the user. The more data is taught, the more information is available for the optimization of the defect classes.

Users can apply the generated data for their own evaluations and statistics. For example, defect accumulations can be recognized and used to improve processes. This is how automatic post-processing can be further optimized.

Due to their outstanding functionality, reflectCONTROL systems achieve maximum area coverage. Defects are located with a positional accuracy of ± 3 mm on the car surface. The unique 3D reconstruction feature allows for each defect to be assigned characteristics such as height, depth and volume. All collected data is saved in an XML file and is thus available at any time.

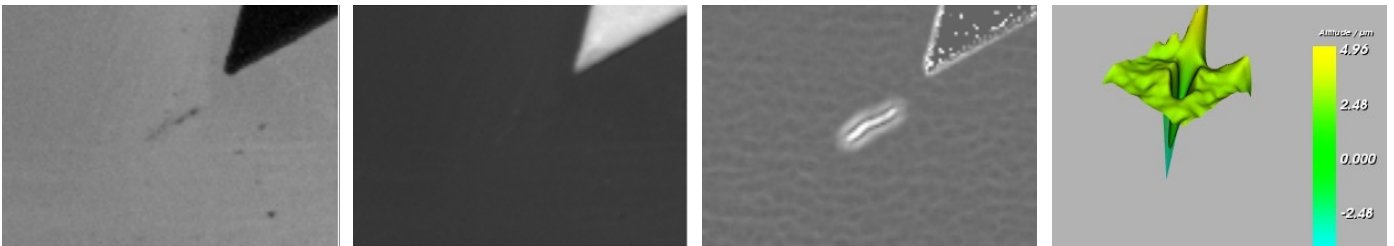

Extensive database with 3D reconstruction

During classification, intelligent algorithms recognize the type of defect, e.g., craters, inclusions or runners. For this purpose, 3D data in addition to 2D data and real geometric characteristics are used.

The classified defects can also be output as 3D data. The exact dimensions of the defect can be accessed in order to initiate extensive analyses. All data can be transferred to the quality management system at any time. The classification and the 3D data form the basis for subsequent processes such as machining and laser marking.

The reflectCONTROL software learns from the acquired data and therefore becomes increasingly "intelligent". The comprehensive database enables the creation of early-alert systems in order to identify both defect chains at an early stage and corresponding potential for improvement. For example, alert thresholds can be set up in the event that certain defect accumulations are exceeded. Heat maps can be used to locate error hotspots and draw conclusions about certain upstream processes.

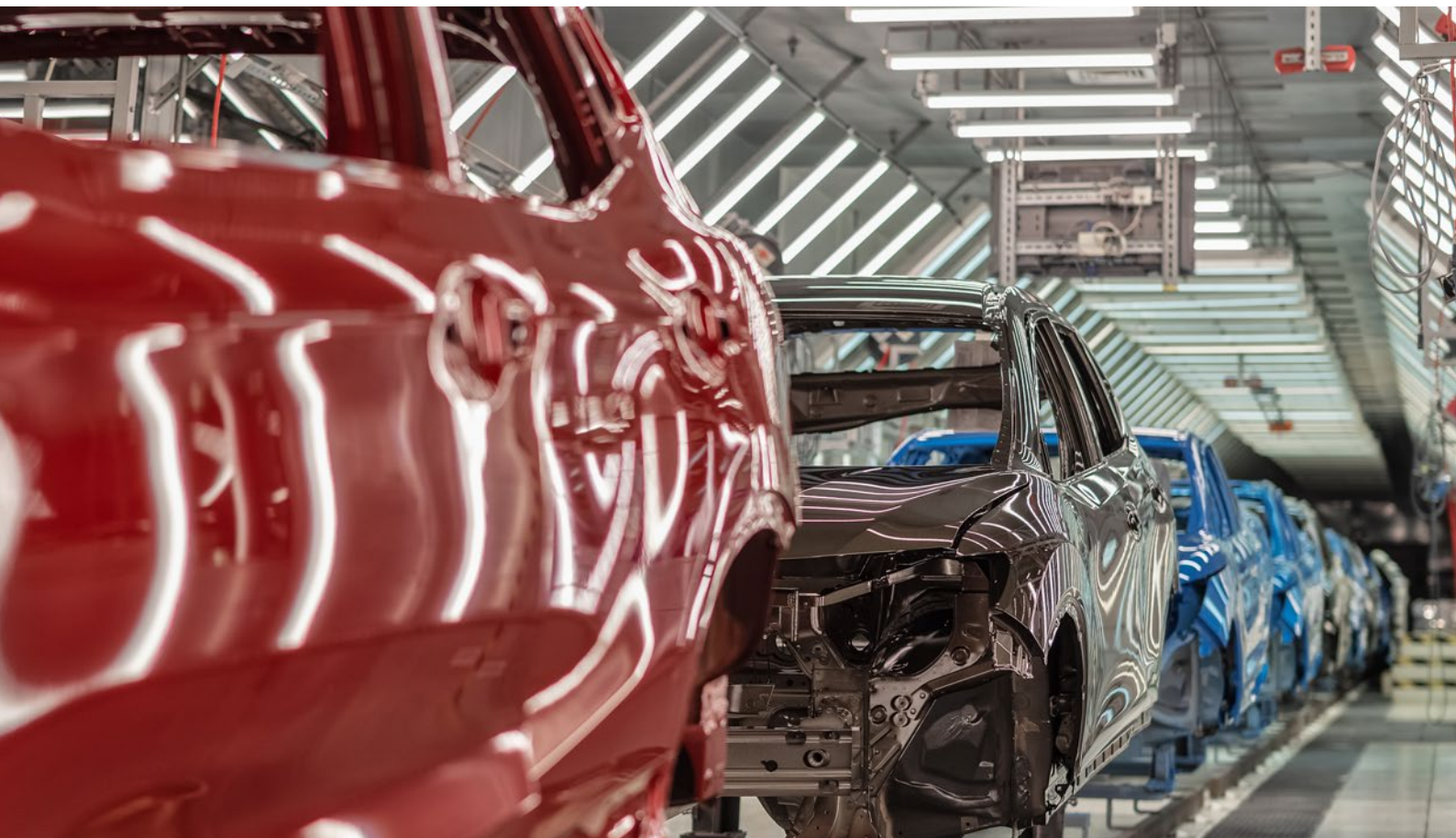

Automatic set-up of all car body colors

The reflectCONTROL inspection systems recognize almost 100% of all relevant defects regardless of the paint color. The repeatability of the measured results remains consistently high.

Furthermore, the innovative reflectCONTROL systems offer a feature for automatic color calibration. This is particularly advantageous for individual paints and new model ranges.

After the production department has transmitted a new color code, the system automatically sets up the parameters and assigns them to the new color code. If desired, the parameter sets can be applied automatically, or forwarded for a manual release process. The new parameter sets are automatically distributed to further inspection cells.

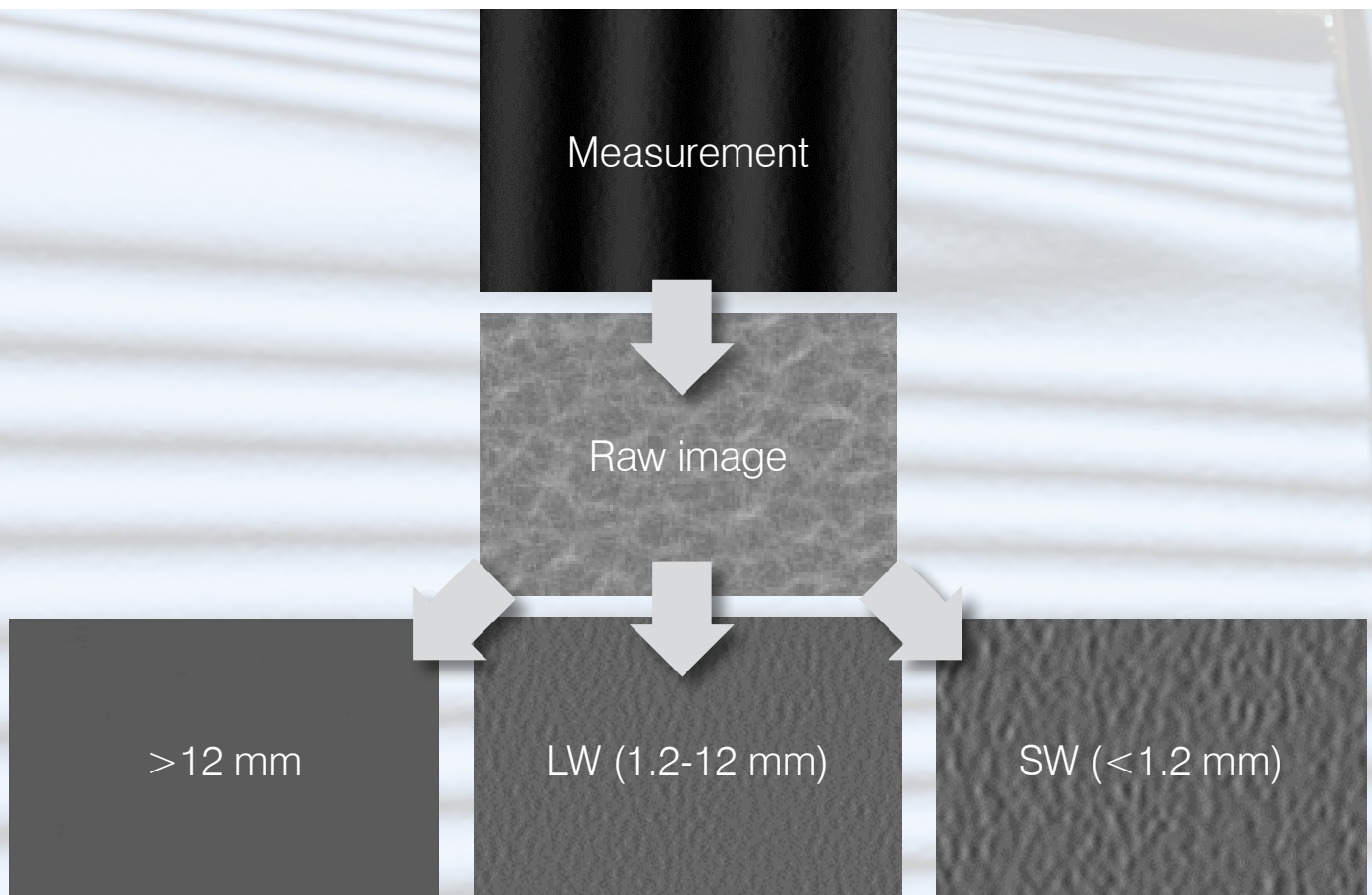

Inline appearance measurement without additional hardware

The reflectCONTROL systems evaluate the appearance based on the existing images. No additional hardware is required for this. For the evaluation of the appearance, the existing paint structure is broken down into its spectral components. These components are summarized in different frequency ranges, for example, short or long wave. The integrated, non-contact appearance evaluation impresses with its high repeatability and is fully integrated.

Any number of measurement positions can be defined for the appearance evaluation, which corresponds to a full-surface appearance measurement - for any number of vehicles. Inline evaluation allows trends to be identified and documented at an early stage.

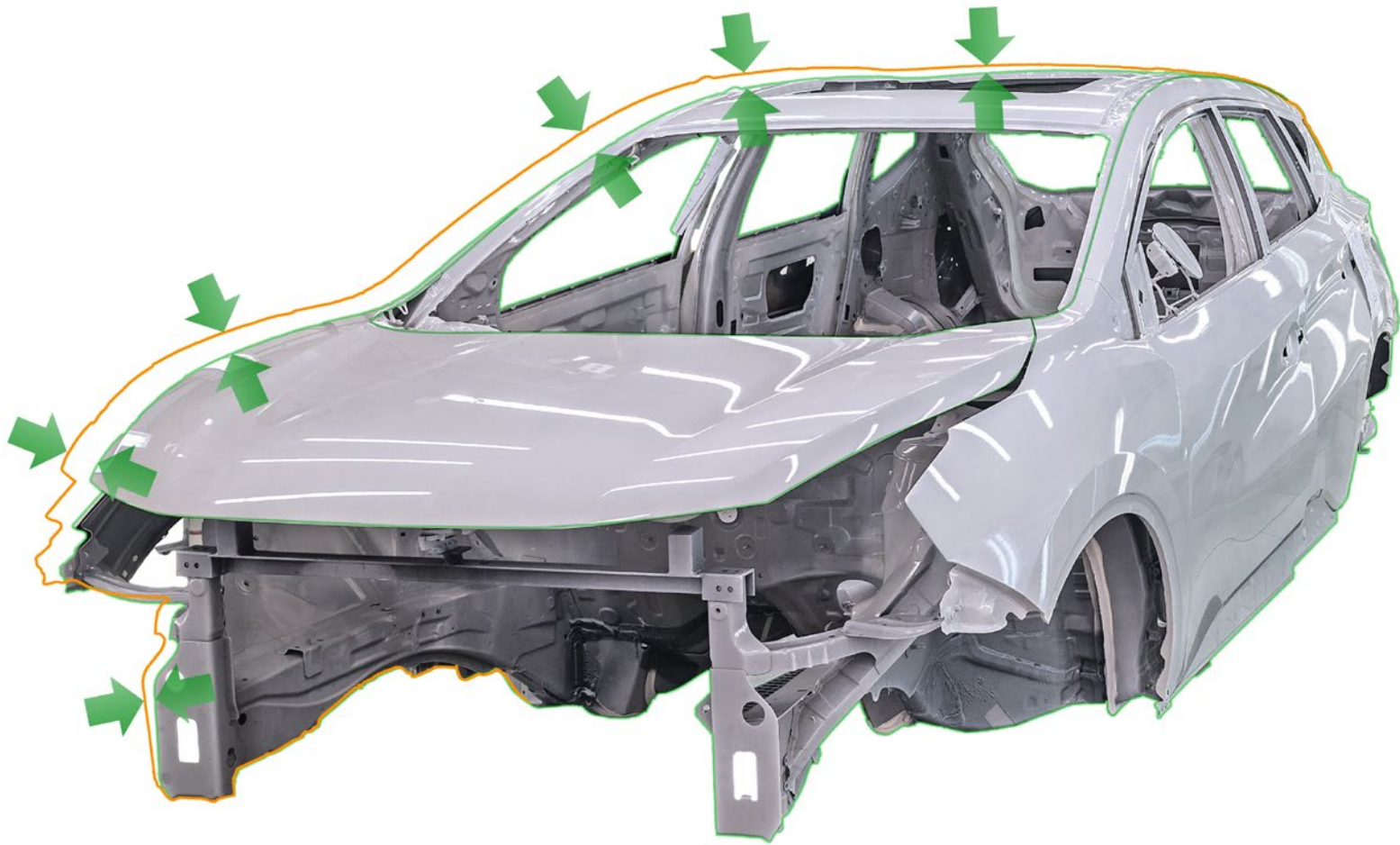

Integrated 6D offset correction

The reflectCONTROL inspection systems have an integrated offset correction that compensates for positional tolerances. After the car body has arrived in the inspection cell, the reflectCONTROL systems detect three geometric characteristics on the car body and, based on these, calculate the body's position in the station. Consequently, the measurement position of the sensors is adapted accordingly which enables a fast, precise and highly repeatable measurement.

Easy teach-in of new car body types

The user can directly teach-in new car body types using the simulation tool which enables path planning under consideration of the required cycle times. Due to the robot-based inspection, new vehicle types can be quickly implemented.

Configurable depending on the throughput

The reflectCONTROL systems consist of sensor, robot, computer as well as software and interface package. Depending on the requirements, different versions of the system are available, which are configurable according to the customer's needs. The number of reflectCONTROL sensors and robots required can be flexibly adapted to the installation space and the required throughput.

Example configurations for a mid-range car

No. of robots	2	3	4
Net inspection time (sec.)	73	49	36
Cycle time (sec.)	96	69	56
Units per hour	38	52	64

Automatic implementation of new car bodies without any change to the hardware

If new models or paint finishes are added to the production line, the inspection can be continued without any changes to the hardware. The robot-guided inspection allows for geometric changes of the car body to be adapted easily.

2 inspection robots

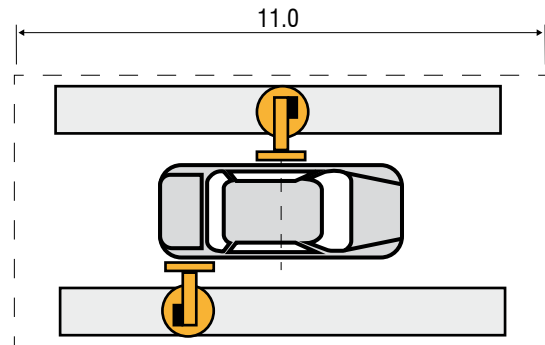

3 inspection robots

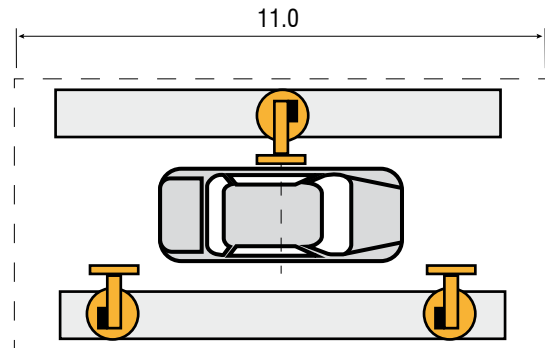

4 inspection robots

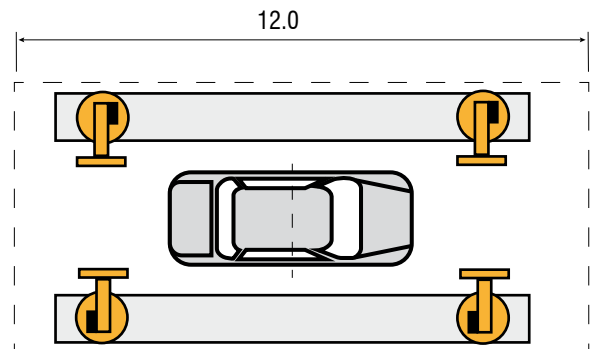

One partner for the entire project

As the general contractor, Micro-Epsilon handles the entire project planning. In addition to measurement technology, this includes robot design, planning, integration into existing control systems and the implementation of data and software interfaces. You also receive packages for regular service and maintenance of the systems.



Static systems or multi-robotic configurations: Just ask us!

100% inline inspection of bodies-in-white

The surfaceCONTROL from Micro-Epsilon is an inspection system for defect detection of bodies-in-white. The system uses the same hardware and software basis as the reflectCONTROL systems and can be seamlessly integrated into the production process.



Automatic repair of defects

High data quality and resolution as well as the positional accuracy of defects form the basis for automatic post-processing. The reflectCONTROL systems transmit the type of defect and its exact position to the repair system. Further robots with active force control and each equipped with a dual-mounted sanding and polishing head take over the automatic repair of defects. With this head, they first grind off the defect and then polish it.

Optical marking of defects

Using a laser marking system, the defect can be marked as processed. Other defects which must be reworked manually can also be marked. The system knows at all times which robot is currently processing which points or which defects have already been processed.